



TANKEN

CK-0014

# ISO Standard Seal



**TANKEN SEAL SEIKO CO.,LTD.**

# ISO標準型アンバランス・シール

## ISO Standard Unbalance Seal

### TYPE UV11-R1 (T3-04000)

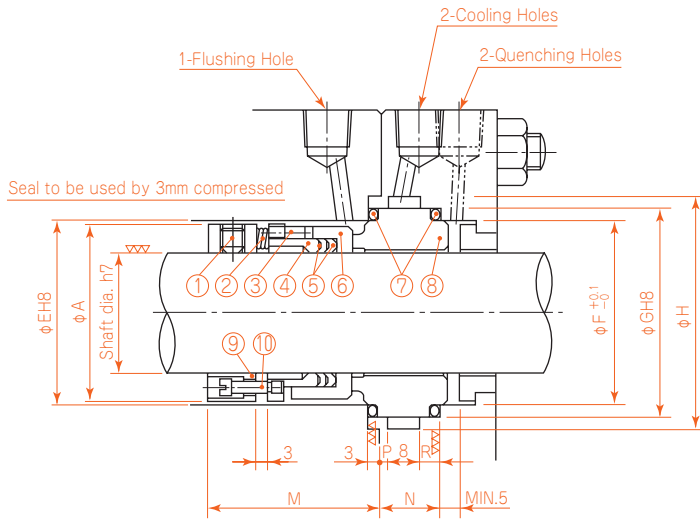

### TYPE UV11-R3 (T3-04004)

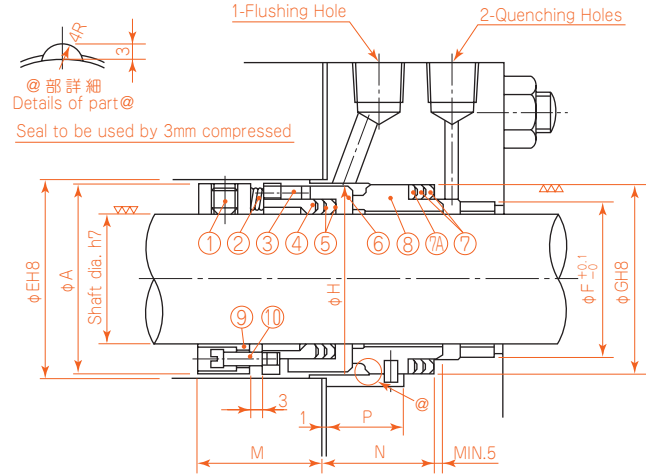

〈注〉 インサートパッキンの“O”リング型もあります。(T3-04003)  
尚インサート部詳細寸法はUV31-R3、T3-04012と同一寸法です。

| No. | Parts Name     | Q'ty | No.     | Parts Name      | Q'ty |
|-----|----------------|------|---------|-----------------|------|
| 1   | Set screws     | List | (R1) 7  | Insert packings | 2    |
| 2   | Springs        | List | 8       | Insert          | 1    |
| 3   | Drive pins     | List | 9       | Coller          | 1    |
| 4   | Comp ring      | 1    | 10      | Spring pins     | List |
| 5   | Shaft packings | 2    | (R3) 7  | Insert Packings | 2    |
| 6   | Seal ring      | 1    | (R3) 7A | Adapter         | 1    |

Pressure -0.03~0.5MPa  
Temp. Water and so on  
Up to 90°C (for above 90°C,  
cooler must be used)  
Oil and so on  
Up to 140°C (for above 140°C,  
cooler must be used)

PTFE used for shaft packing.

| SHAFT DIA | 寸法表 Dimension |     |              |     |     |    |    |   |   |              |     |      |    |    |    | 部品数量表 Q'ty |    |   |   |   |
|-----------|---------------|-----|--------------|-----|-----|----|----|---|---|--------------|-----|------|----|----|----|------------|----|---|---|---|
|           | A             | E   | UV11-R1 Type |     |     |    |    |   |   | UV11-R3 Type |     |      |    |    |    |            | ①  | ② | ③ | ⑩ |
|           |               |     | F            | G   | H   | M  | N  | P | R | F            | G   | H    | M  | N  | P  |            |    |   |   |   |
| 20        | 34            | 36  | 36           | 42  | 48  | 43 | 15 | 2 | 5 | 27.3         | 34  | 34.5 | 36 | 26 | 18 | 2          | 4  | 2 | 2 |   |
| 22        | 36            | 38  | 38           | 44  | 50  | 43 | 15 | 2 | 5 | 29.3         | 36  | 36.5 | 36 | 26 | 18 | 2          | 4  | 2 | 2 |   |
| 24        | 38            | 40  | 40           | 46  | 52  | 43 | 15 | 2 | 5 | 31.3         | 38  | 38.5 | 36 | 26 | 18 | 2          | 4  | 2 | 2 |   |
| 25        | 39            | 41  | 41           | 47  | 53  | 43 | 15 | 2 | 5 | 32.3         | 39  | 39.5 | 36 | 26 | 18 | 2          | 4  | 2 | 2 |   |
| 26        | 40            | 42  | 42           | 48  | 54  | 43 | 15 | 2 | 5 | 33.3         | 40  | 40.5 | 36 | 26 | 18 | 2          | 4  | 2 | 2 |   |
| 28        | 42            | 44  | 44           | 50  | 56  | 43 | 15 | 2 | 5 | 35.3         | 42  | 42.5 | 36 | 26 | 18 | 2          | 4  | 2 | 2 |   |
| 30        | 44            | 46  | 46           | 52  | 58  | 43 | 15 | 2 | 5 | 37.3         | 44  | 44.5 | 36 | 26 | 18 | 2          | 6  | 2 | 2 |   |
| 32        | 46            | 48  | 48           | 54  | 60  | 43 | 15 | 2 | 5 | 39.3         | 46  | 46.5 | 36 | 26 | 18 | 2          | 6  | 2 | 2 |   |
| 33        | 47            | 49  | 49           | 55  | 61  | 43 | 15 | 2 | 5 | 40.3         | 47  | 47.5 | 36 | 26 | 18 | 2          | 6  | 2 | 2 |   |
| 35        | 49            | 51  | 51           | 57  | 63  | 43 | 15 | 2 | 5 | 42.3         | 49  | 49.5 | 36 | 26 | 18 | 2          | 6  | 2 | 2 |   |
| 38        | 54            | 58  | 58           | 64  | 70  | 47 | 15 | 2 | 5 | 49.3         | 56  | 56.5 | 37 | 31 | 22 | 2          | 8  | 2 | 4 |   |
| 40        | 56            | 60  | 60           | 66  | 72  | 47 | 15 | 2 | 5 | 51.3         | 58  | 58.5 | 37 | 31 | 22 | 2          | 8  | 2 | 4 |   |
| 43        | 59            | 63  | 63           | 69  | 75  | 47 | 15 | 2 | 5 | 54.3         | 61  | 61.5 | 37 | 31 | 22 | 2          | 8  | 2 | 4 |   |
| 45        | 61            | 65  | 65           | 71  | 77  | 47 | 15 | 2 | 5 | 56.3         | 63  | 63.5 | 37 | 31 | 22 | 2          | 8  | 2 | 4 |   |
| 48        | 64            | 68  | 68           | 74  | 80  | 47 | 15 | 2 | 5 | 59.3         | 66  | 66.5 | 37 | 31 | 22 | 2          | 8  | 2 | 4 |   |
| 50        | 68            | 70  | 70           | 76  | 82  | 48 | 17 | 3 | 6 | 61.3         | 68  | 68.5 | 38 | 31 | 22 | 2          | 12 | 4 | 4 |   |
| 53        | 71            | 73  | 73           | 79  | 85  | 48 | 17 | 3 | 6 | 64.3         | 71  | 71.5 | 38 | 31 | 22 | 2          | 12 | 4 | 4 |   |
| 55        | 73            | 75  | 75           | 81  | 87  | 48 | 17 | 3 | 6 | 66.3         | 73  | 73.5 | 38 | 31 | 22 | 2          | 12 | 4 | 4 |   |
| 58        | 76            | 83  | 83           | 89  | 95  | 48 | 17 | 3 | 6 | 71.3         | 78  | 80   | 38 | 31 | 22 | 2          | 12 | 4 | 4 |   |
| 60        | 78            | 85  | 85           | 91  | 97  | 48 | 17 | 3 | 6 | 73.3         | 80  | 82   | 38 | 31 | 22 | 2          | 12 | 4 | 4 |   |
| 63        | 81            | 88  | 88           | 94  | 100 | 48 | 17 | 3 | 6 | 76.3         | 83  | 85   | 38 | 31 | 22 | 2          | 12 | 4 | 4 |   |
| 65        | 83            | 90  | 90           | 96  | 102 | 48 | 17 | 3 | 6 | 78.3         | 85  | 87   | 38 | 31 | 22 | 2          | 12 | 4 | 4 |   |
| 68        | 88            | 93  | 93           | 99  | 105 | 48 | 17 | 3 | 6 | 83.3         | 90  | 91   | 38 | 34 | 24 | 2          | 12 | 4 | 4 |   |
| 70        | 90            | 95  | 95           | 101 | 107 | 48 | 17 | 3 | 6 | 85.3         | 92  | 93   | 38 | 34 | 24 | 2          | 16 | 4 | 4 |   |
| 75        | 95            | 104 | 104          | 110 | 116 | 48 | 17 | 3 | 6 | 90.3         | 97  | 100  | 38 | 34 | 24 | 2          | 16 | 4 | 4 |   |
| 80        | 100           | 109 | 109          | 115 | 121 | 48 | 17 | 3 | 6 | 98.3         | 105 | 106  | 38 | 34 | 24 | 2          | 16 | 4 | 4 |   |
| 85        | 105           | 114 | 114          | 120 | 126 | 50 | 19 | 4 | 7 | 103.3        | 110 | 111  | 38 | 36 | 26 | 2          | 16 | 4 | 4 |   |
| 90        | 110           | 119 | 119          | 125 | 131 | 50 | 19 | 4 | 7 | 108.3        | 115 | 116  | 38 | 36 | 26 | 2          | 16 | 4 | 4 |   |
| 95        | 115           | 124 | 124          | 130 | 136 | 50 | 19 | 4 | 7 | 113.3        | 120 | 121  | 38 | 36 | 26 | 2          | 16 | 4 | 4 |   |
| 100       | 122           | 129 | 129          | 135 | 141 | 51 | 19 | 4 | 7 | 118.3        | 125 | 126  | 39 | 36 | 26 | 3          | 20 | 4 | 4 |   |

# ISO標準型バランス・シール

## ISO Standard balance Seal

### TYPE **BV11-R1** (T3-04001)

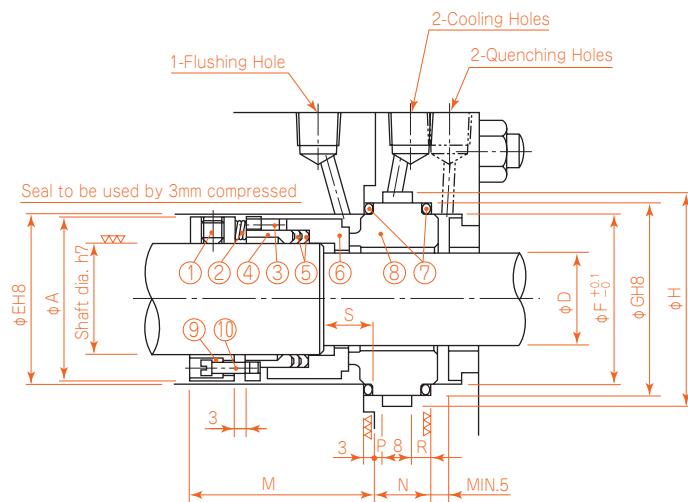

### TYPE **BV11-R3** (T3-04006)

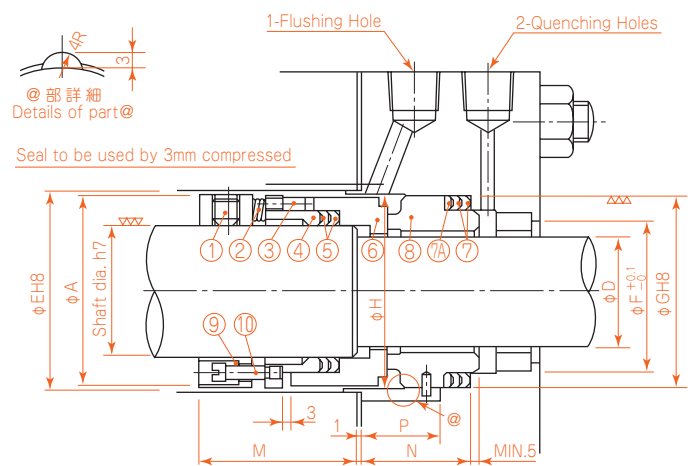

〈注〉 インサートパッキンの“O”リング型もあります。(T3-04005)  
 尚インサート部詳細寸法はBV31-R3、T3-04014と同一寸法です。

| No. | Parts Name     | Q'ty | No.     | Parts Name      | Q'ty |
|-----|----------------|------|---------|-----------------|------|
| 1   | Set screws     | List | (R1) 7  | Insert packings | 2    |
| 2   | Springs        | List | 8       | Insert          | 1    |
| 3   | Drive pins     | List | 9       | Coller          | 1    |
| 4   | Comp ring      | 1    | 10      | Spring pins     | List |
| 5   | Shaft packings | 2    | (R3) 7  | Insert Packings | 2    |
| 6   | Seal ring      | 1    | (R3) 7A | Adapter         | 1    |

Used for high pressure.  
 Pressure -0.05~2.5MPa (Special designing for above 2.5MPa)  
 Temp. Water and so on  
 Up to 90°C (for above 90°C, cooler must be used)  
 Oil and so on  
 Up to 140°C (for above 140°C, cooler must be used)

PTFE used for shaft packing.

| SHAFT DIA | 寸法表 Dimension |    |     |              |     |     |    |    |   |   |    |              |     |      |    |    | 部品数量表 Q'ty |   |    |   |   |
|-----------|---------------|----|-----|--------------|-----|-----|----|----|---|---|----|--------------|-----|------|----|----|------------|---|----|---|---|
|           | A             | D  | E   | BV11-R1 Type |     |     |    |    |   |   |    | BV11-R3 Type |     |      |    |    |            | ① | ②  | ③ | ⑩ |
|           |               |    |     | F            | G   | H   | M  | N  | P | R | S  | F            | G   | H    | M  | N  | P          |   |    |   |   |
| 20        | 34            | 16 | 36  | 36           | 42  | 48  | 50 | 15 | 2 | 5 | 14 | 27.3         | 34  | 34.5 | 36 | 26 | 18         | 2 | 4  | 2 | 2 |
| 22        | 36            | 18 | 38  | 38           | 44  | 50  | 50 | 15 | 2 | 5 | 14 | 29.3         | 36  | 36.5 | 36 | 26 | 18         | 2 | 4  | 2 | 2 |
| 24        | 38            | 20 | 40  | 40           | 46  | 52  | 50 | 15 | 2 | 5 | 14 | 31.3         | 38  | 38.5 | 36 | 26 | 18         | 2 | 4  | 2 | 2 |
| 25        | 39            | 21 | 41  | 41           | 47  | 53  | 50 | 15 | 2 | 5 | 14 | 32.3         | 39  | 39.5 | 36 | 26 | 18         | 2 | 4  | 2 | 2 |
| 26        | 40            | 22 | 42  | 42           | 48  | 54  | 50 | 15 | 2 | 5 | 14 | 33.3         | 40  | 40.5 | 36 | 26 | 18         | 2 | 4  | 2 | 2 |
| 28        | 42            | 24 | 44  | 44           | 50  | 56  | 50 | 15 | 2 | 5 | 14 | 35.3         | 42  | 42.5 | 36 | 26 | 18         | 2 | 4  | 2 | 2 |
| 30        | 44            | 25 | 46  | 46           | 52  | 58  | 50 | 15 | 2 | 5 | 14 | 37.3         | 44  | 44.5 | 36 | 26 | 18         | 2 | 6  | 2 | 2 |
| 32        | 46            | 27 | 48  | 48           | 54  | 60  | 50 | 15 | 2 | 5 | 14 | 39.3         | 46  | 46.5 | 36 | 26 | 18         | 2 | 6  | 2 | 2 |
| 33        | 47            | 28 | 49  | 49           | 55  | 61  | 50 | 15 | 2 | 5 | 14 | 40.3         | 47  | 47.5 | 36 | 26 | 18         | 2 | 6  | 2 | 2 |
| 35        | 49            | 30 | 51  | 51           | 57  | 63  | 50 | 15 | 2 | 5 | 14 | 42.3         | 49  | 49.5 | 36 | 26 | 18         | 2 | 8  | 2 | 4 |
| 38        | 54            | 32 | 58  | 58           | 64  | 70  | 54 | 15 | 2 | 5 | 17 | 49.3         | 56  | 56.5 | 37 | 31 | 22         | 2 | 8  | 2 | 4 |
| 40        | 56            | 35 | 60  | 60           | 66  | 73  | 54 | 15 | 2 | 5 | 17 | 51.3         | 58  | 58.5 | 37 | 31 | 22         | 2 | 8  | 2 | 4 |
| 43        | 59            | 38 | 63  | 63           | 69  | 75  | 54 | 15 | 2 | 5 | 17 | 54.3         | 61  | 61.5 | 37 | 31 | 22         | 2 | 8  | 2 | 4 |
| 45        | 61            | 40 | 65  | 65           | 71  | 77  | 54 | 15 | 2 | 5 | 17 | 56.3         | 63  | 63.5 | 37 | 31 | 22         | 2 | 8  | 2 | 4 |
| 48        | 64            | 43 | 68  | 68           | 74  | 80  | 54 | 15 | 2 | 5 | 17 | 59.3         | 66  | 66.5 | 37 | 31 | 22         | 2 | 8  | 2 | 4 |
| 50        | 68            | 45 | 70  | 70           | 76  | 82  | 55 | 17 | 3 | 6 | 17 | 61.3         | 68  | 68.5 | 38 | 31 | 22         | 2 | 12 | 4 | 4 |
| 53        | 71            | 48 | 73  | 73           | 79  | 85  | 55 | 17 | 3 | 6 | 17 | 64.3         | 71  | 71.5 | 38 | 31 | 22         | 2 | 12 | 4 | 4 |
| 55        | 73            | 50 | 75  | 75           | 81  | 87  | 55 | 17 | 3 | 6 | 17 | 66.3         | 73  | 73.5 | 38 | 31 | 22         | 2 | 12 | 4 | 4 |
| 58        | 76            | 53 | 83  | 83           | 89  | 95  | 55 | 17 | 3 | 6 | 17 | 71.3         | 78  | 80   | 38 | 31 | 22         | 2 | 12 | 4 | 4 |
| 60        | 78            | 55 | 85  | 85           | 91  | 97  | 55 | 17 | 3 | 6 | 17 | 73.3         | 80  | 82   | 38 | 31 | 22         | 2 | 12 | 4 | 4 |
| 63        | 81            | 58 | 88  | 88           | 94  | 100 | 55 | 17 | 3 | 6 | 17 | 76.3         | 83  | 85   | 38 | 31 | 22         | 2 | 12 | 4 | 4 |
| 65        | 83            | 60 | 90  | 90           | 96  | 102 | 55 | 17 | 3 | 6 | 17 | 78.3         | 85  | 87   | 38 | 31 | 22         | 2 | 12 | 4 | 4 |
| 68        | 88            | 63 | 93  | 93           | 99  | 105 | 55 | 17 | 3 | 6 | 17 | 83.3         | 90  | 91   | 38 | 34 | 24         | 2 | 16 | 4 | 4 |
| 70        | 90            | 65 | 95  | 95           | 101 | 107 | 55 | 17 | 3 | 6 | 17 | 85.3         | 92  | 93   | 38 | 34 | 24         | 2 | 16 | 4 | 4 |
| 75        | 95            | 70 | 104 | 104          | 110 | 116 | 55 | 17 | 3 | 6 | 17 | 90.3         | 97  | 100  | 38 | 34 | 24         | 2 | 16 | 4 | 4 |
| 80        | 100           | 75 | 109 | 109          | 115 | 121 | 55 | 17 | 3 | 6 | 17 | 98.3         | 105 | 106  | 38 | 34 | 24         | 2 | 16 | 4 | 4 |
| 85        | 105           | 80 | 114 | 114          | 120 | 126 | 57 | 19 | 4 | 7 | 19 | 103.3        | 110 | 111  | 38 | 36 | 26         | 2 | 16 | 4 | 4 |
| 90        | 110           | 85 | 119 | 119          | 125 | 131 | 57 | 19 | 4 | 7 | 19 | 108.3        | 115 | 116  | 38 | 36 | 26         | 2 | 16 | 4 | 4 |
| 95        | 115           | 90 | 124 | 124          | 130 | 136 | 57 | 19 | 4 | 7 | 19 | 113.3        | 120 | 121  | 38 | 36 | 26         | 2 | 16 | 4 | 4 |
| 100       | 122           | 95 | 129 | 129          | 135 | 141 | 58 | 19 | 4 | 7 | 19 | 118.3        | 125 | 126  | 39 | 36 | 26         | 3 | 20 | 4 | 4 |

# ISO標準型アンバランス・シール

## ISO Standard Unbalance Seal

### TYPE UV31-R1 (T3-04009)

### TYPE UV31-R3 (T3-04012)

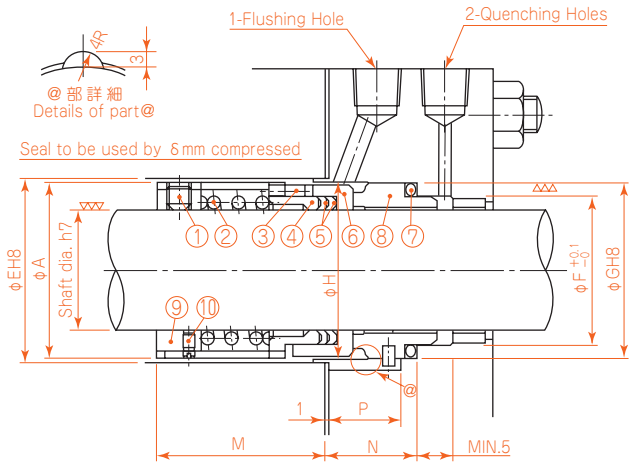
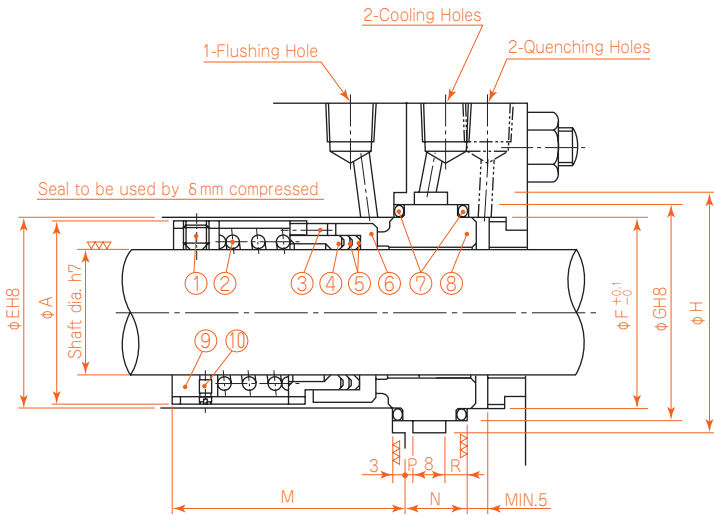

〈注〉 インサートパッキンの“V”リング型もあります。(T3-04013)  
尚インサート部詳細寸法はUV11-R3、T3-04004と同一寸法です。

Pressure -0.03~0.5MPa  
Temp. Same as UV11  
Viscosity Up to 10,000 cp  
Speed Up to 35m/sec

| No. | Parts Name     | Q'ty | No. | Parts Name      | Q'ty   |
|-----|----------------|------|-----|-----------------|--------|
| 1   | Set screws     | 3    | 6   | Seal ring       | 1      |
| 2   | Springs        | 1    | 7   | Insert packings | 1 or 2 |
| 3   | Drive pins     | List | 8   | Insert          | 1      |
| 4   | Comp ring      | 1    | 9   | Coller          | 1      |
| 5   | Shaft packings | 2    | 10  | Spring pins     | 2      |

| 寸法表 Dimension |     |     |              |     |     |     |    |   |   |              |     |      |    |    |    | 部品数量表 Q'ty |   |
|---------------|-----|-----|--------------|-----|-----|-----|----|---|---|--------------|-----|------|----|----|----|------------|---|
| SHAFT DIA     | A   | E   | UV31-R1 Type |     |     |     |    |   |   | UV31-R3 Type |     |      |    |    |    | δ          | ③ |
|               |     |     | F            | G   | H   | M   | N  | P | R | F            | G   | H    | M  | N  | P  |            |   |
| 20            | 34  | 36  | 36           | 42  | 48  | 53  | 15 | 2 | 5 | 27.3         | 34  | 34.5 | 39 | 23 | 18 | 4.5        | 2 |
| 22            | 36  | 38  | 38           | 44  | 50  | 53  | 15 | 2 | 5 | 29.3         | 36  | 36.5 | 39 | 23 | 18 | 4.5        | 2 |
| 24            | 38  | 40  | 40           | 46  | 52  | 53  | 15 | 2 | 5 | 31.3         | 38  | 38.5 | 39 | 23 | 18 | 4.5        | 2 |
| 25            | 39  | 41  | 41           | 47  | 53  | 55  | 15 | 2 | 5 | 32.3         | 39  | 39.5 | 41 | 23 | 18 | 4.5        | 2 |
| 26            | 40  | 42  | 42           | 48  | 54  | 55  | 15 | 2 | 5 | 33.3         | 40  | 40.5 | 41 | 23 | 18 | 4.5        | 2 |
| 28            | 42  | 44  | 44           | 50  | 56  | 55  | 15 | 2 | 5 | 35.3         | 42  | 42.5 | 41 | 23 | 18 | 4.5        | 2 |
| 30            | 44  | 46  | 46           | 52  | 58  | 56  | 15 | 2 | 5 | 37.3         | 44  | 44.5 | 42 | 23 | 18 | 4.5        | 2 |
| 32            | 46  | 48  | 48           | 54  | 60  | 56  | 15 | 2 | 5 | 39.3         | 46  | 46.5 | 42 | 23 | 18 | 4.5        | 2 |
| 33            | 47  | 49  | 49           | 55  | 61  | 56  | 15 | 2 | 5 | 40.3         | 47  | 47.5 | 42 | 23 | 18 | 4.5        | 2 |
| 35            | 49  | 51  | 51           | 57  | 63  | 57  | 15 | 2 | 5 | 42.3         | 49  | 49.5 | 43 | 23 | 18 | 4.5        | 2 |
| 38            | 54  | 58  | 58           | 64  | 70  | 64  | 15 | 2 | 5 | 49.3         | 56  | 56.5 | 47 | 28 | 22 | 4          | 2 |
| 40            | 56  | 60  | 60           | 66  | 73  | 64  | 15 | 2 | 5 | 51.3         | 58  | 58.5 | 47 | 28 | 22 | 4          | 2 |
| 43            | 59  | 63  | 63           | 69  | 75  | 66  | 15 | 2 | 5 | 54.3         | 61  | 61.5 | 49 | 28 | 22 | 4          | 2 |
| 45            | 61  | 65  | 65           | 71  | 77  | 66  | 15 | 2 | 5 | 56.3         | 63  | 63.5 | 49 | 28 | 22 | 4          | 2 |
| 48            | 64  | 68  | 68           | 74  | 80  | 66  | 15 | 2 | 5 | 59.3         | 66  | 66.5 | 49 | 28 | 22 | 4          | 2 |
| 50            | 68  | 70  | 70           | 76  | 82  | 68  | 17 | 3 | 6 | 61.3         | 68  | 68.5 | 51 | 28 | 22 | 4          | 4 |
| 53            | 71  | 73  | 73           | 79  | 85  | 68  | 17 | 3 | 6 | 64.3         | 71  | 71.5 | 51 | 28 | 22 | 4          | 4 |
| 55            | 73  | 75  | 75           | 81  | 87  | 72  | 17 | 3 | 6 | 66.3         | 73  | 73.5 | 55 | 28 | 22 | 4          | 4 |
| 58            | 76  | 83  | 83           | 89  | 95  | 72  | 17 | 3 | 6 | 71.3         | 78  | 80   | 55 | 28 | 22 | 4          | 4 |
| 60            | 78  | 85  | 85           | 91  | 97  | 72  | 17 | 3 | 6 | 73.3         | 80  | 82   | 55 | 28 | 22 | 4          | 4 |
| 63            | 81  | 88  | 88           | 94  | 100 | 72  | 17 | 3 | 6 | 76.3         | 83  | 85   | 55 | 28 | 22 | 4          | 4 |
| 65            | 83  | 90  | 90           | 96  | 102 | 75  | 17 | 3 | 6 | 78.3         | 85  | 87   | 58 | 28 | 22 | 4          | 4 |
| 68            | 88  | 93  | 93           | 99  | 105 | 75  | 17 | 3 | 6 | 83.3         | 90  | 91   | 58 | 31 | 24 | 4          | 4 |
| 70            | 90  | 95  | 95           | 101 | 107 | 77  | 17 | 3 | 6 | 85.3         | 92  | 93   | 60 | 31 | 24 | 4          | 4 |
| 75            | 95  | 104 | 104          | 110 | 116 | 77  | 17 | 3 | 6 | 90.3         | 97  | 100  | 60 | 31 | 24 | 4          | 4 |
| 80            | 100 | 109 | 109          | 115 | 121 | 79  | 17 | 3 | 6 | 98.3         | 105 | 106  | 62 | 31 | 24 | 4          | 4 |
| 85            | 105 | 114 | 114          | 120 | 126 | 81  | 19 | 4 | 7 | 103.3        | 110 | 111  | 62 | 33 | 26 | 4          | 4 |
| 90            | 112 | 119 | 119          | 125 | 131 | 84  | 19 | 4 | 7 | 108.3        | 115 | 116  | 65 | 33 | 26 | 4          | 4 |
| 95            | 117 | 124 | 124          | 130 | 136 | 84  | 19 | 4 | 7 | 113.3        | 120 | 121  | 65 | 33 | 26 | 4          | 4 |
| 100           | 124 | 129 | 129          | 135 | 141 | 102 | 19 | 4 | 7 | 118.3        | 125 | 126  | 83 | 33 | 26 | 4.5        | 4 |

# ISO標準型バランス・シール

## ISO Standard balance Seal

### TYPE **BV31-R1** (T3-04010)

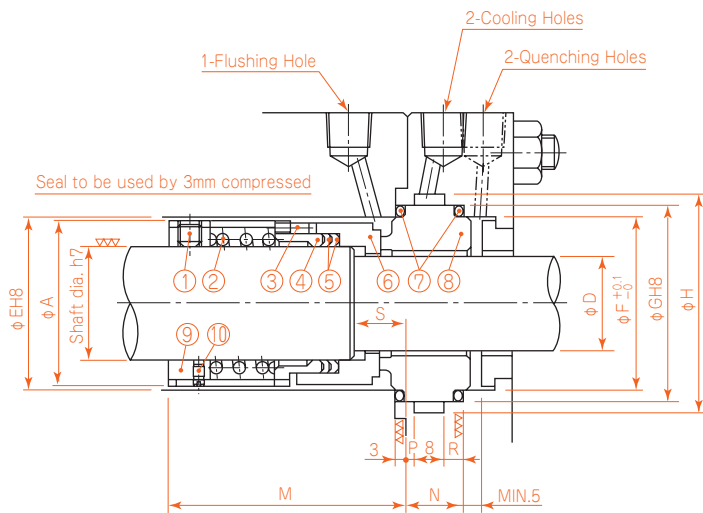

### TYPE **BV31-R3** (T3-04014)

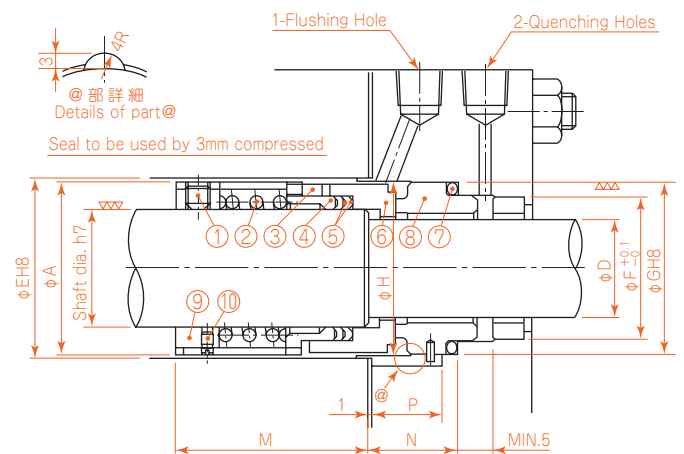

〈注〉 インサートパッキンの“V”リング型もあります。(T3-04015)  
尚インサート部詳細寸法はBV11-R3、T3-04006と同一寸法です。

Pressure -0.05~2.5MPa  
(Special designing for above 2.5MPa)  
Temp. Same as BV11  
Viscosity Up to 10,000 cp  
Speed Up to 35m/sec

| No. | Parts Name     | Q'ty | No. | Parts Name      | Q'ty   |
|-----|----------------|------|-----|-----------------|--------|
| 1   | Set screws     | 3    | 6   | Seal ring       | 1      |
| 2   | Springs        | 1    | 7   | Insert packings | 1 or 2 |
| 3   | Drive pins     | List | 8   | Insert          | 1      |
| 4   | Comp ring      | 1    | 9   | Coller          | 1      |
| 5   | Shaft packings | 2    | 10  | Spring pins     | 2      |

| SHAFT DIA | 寸法表 Dimension |    |     |              |     |     |     |    |   |   |    |       |              |      |    |    |    | 部品数量表 Q'ty |   |
|-----------|---------------|----|-----|--------------|-----|-----|-----|----|---|---|----|-------|--------------|------|----|----|----|------------|---|
|           | A             | D  | E   | BV31-R1 Type |     |     |     |    |   |   |    |       | BV31-R3 Type |      |    |    |    | φ          | ③ |
|           |               |    |     | F            | G   | H   | M   | N  | P | R | S  | F     | G            | H    | M  | N  | P  |            |   |
| 20        | 34            | 16 | 36  | 36           | 42  | 48  | 60  | 15 | 2 | 5 | 14 | 27.3  | 34           | 34.5 | 46 | 23 | 18 | 4.5        | 2 |
| 22        | 36            | 18 | 38  | 38           | 44  | 50  | 60  | 15 | 2 | 5 | 14 | 29.3  | 36           | 36.5 | 46 | 23 | 18 | 4.5        | 2 |
| 24        | 38            | 20 | 40  | 40           | 46  | 52  | 60  | 15 | 2 | 5 | 14 | 31.3  | 38           | 38.5 | 46 | 23 | 18 | 4.5        | 2 |
| 25        | 39            | 21 | 41  | 41           | 47  | 53  | 62  | 15 | 2 | 5 | 14 | 32.3  | 39           | 39.5 | 48 | 23 | 18 | 4.5        | 2 |
| 26        | 40            | 22 | 42  | 42           | 48  | 54  | 62  | 15 | 2 | 5 | 14 | 33.3  | 40           | 40.5 | 48 | 23 | 18 | 4.5        | 2 |
| 28        | 42            | 24 | 44  | 44           | 50  | 56  | 62  | 15 | 2 | 5 | 14 | 35.3  | 42           | 42.5 | 48 | 23 | 18 | 4.5        | 2 |
| 30        | 44            | 25 | 46  | 46           | 52  | 58  | 63  | 15 | 2 | 5 | 14 | 37.3  | 44           | 44.5 | 49 | 23 | 18 | 4.5        | 2 |
| 32        | 46            | 27 | 48  | 48           | 54  | 60  | 63  | 15 | 2 | 5 | 14 | 39.3  | 46           | 46.5 | 49 | 23 | 18 | 4.5        | 2 |
| 33        | 47            | 28 | 49  | 49           | 55  | 61  | 63  | 15 | 2 | 5 | 14 | 40.3  | 47           | 47.5 | 49 | 23 | 18 | 4.5        | 2 |
| 35        | 49            | 30 | 51  | 51           | 57  | 63  | 64  | 15 | 2 | 5 | 14 | 42.3  | 49           | 49.5 | 50 | 23 | 18 | 4.5        | 2 |
| 38        | 54            | 32 | 58  | 58           | 64  | 70  | 71  | 15 | 2 | 5 | 17 | 49.3  | 56           | 56.5 | 54 | 28 | 22 | 4          | 2 |
| 40        | 56            | 35 | 60  | 60           | 66  | 73  | 71  | 15 | 2 | 5 | 17 | 51.3  | 58           | 58.5 | 54 | 28 | 22 | 4          | 2 |
| 43        | 59            | 38 | 63  | 63           | 69  | 75  | 73  | 15 | 2 | 5 | 17 | 54.3  | 61           | 61.5 | 56 | 28 | 22 | 4          | 2 |
| 45        | 61            | 40 | 65  | 65           | 71  | 77  | 73  | 15 | 2 | 5 | 17 | 56.3  | 63           | 63.5 | 56 | 28 | 22 | 4          | 2 |
| 48        | 64            | 43 | 68  | 68           | 74  | 80  | 73  | 15 | 2 | 5 | 17 | 59.3  | 66           | 66.5 | 56 | 28 | 22 | 4          | 2 |
| 50        | 68            | 45 | 70  | 70           | 76  | 82  | 75  | 17 | 3 | 6 | 17 | 61.3  | 68           | 68.5 | 58 | 28 | 22 | 4          | 4 |
| 53        | 71            | 48 | 73  | 73           | 79  | 85  | 75  | 17 | 3 | 6 | 17 | 64.3  | 71           | 71.5 | 58 | 28 | 22 | 4          | 4 |
| 55        | 73            | 50 | 75  | 75           | 81  | 87  | 79  | 17 | 3 | 6 | 17 | 66.3  | 73           | 73.5 | 62 | 28 | 22 | 4          | 4 |
| 58        | 76            | 53 | 83  | 83           | 89  | 95  | 79  | 17 | 3 | 6 | 17 | 71.3  | 78           | 80   | 62 | 28 | 22 | 4          | 4 |
| 60        | 78            | 55 | 85  | 85           | 91  | 97  | 79  | 17 | 3 | 6 | 17 | 73.3  | 80           | 82   | 62 | 28 | 22 | 4          | 4 |
| 63        | 81            | 58 | 88  | 88           | 94  | 100 | 79  | 17 | 3 | 6 | 17 | 76.3  | 83           | 85   | 62 | 28 | 22 | 4          | 4 |
| 65        | 83            | 60 | 90  | 90           | 96  | 102 | 82  | 17 | 3 | 6 | 17 | 78.3  | 85           | 87   | 65 | 28 | 22 | 4          | 4 |
| 68        | 88            | 63 | 93  | 93           | 99  | 105 | 82  | 17 | 3 | 6 | 17 | 83.3  | 90           | 91   | 65 | 31 | 24 | 4          | 4 |
| 70        | 90            | 65 | 95  | 95           | 101 | 107 | 84  | 17 | 3 | 6 | 17 | 85.3  | 92           | 93   | 67 | 31 | 24 | 4          | 4 |
| 75        | 95            | 70 | 104 | 104          | 110 | 116 | 84  | 17 | 3 | 6 | 17 | 90.3  | 97           | 100  | 67 | 31 | 24 | 4          | 4 |
| 80        | 100           | 75 | 109 | 109          | 115 | 121 | 86  | 17 | 3 | 6 | 17 | 98.3  | 105          | 106  | 69 | 31 | 24 | 4          | 4 |
| 85        | 105           | 80 | 114 | 114          | 120 | 126 | 88  | 19 | 4 | 7 | 19 | 103.3 | 110          | 111  | 69 | 33 | 26 | 4          | 4 |
| 90        | 110           | 85 | 119 | 119          | 125 | 131 | 91  | 19 | 4 | 7 | 19 | 108.3 | 115          | 116  | 72 | 33 | 26 | 4          | 4 |
| 95        | 115           | 90 | 124 | 124          | 130 | 136 | 91  | 19 | 4 | 7 | 19 | 113.3 | 120          | 121  | 72 | 33 | 26 | 4          | 4 |
| 100       | 122           | 95 | 129 | 129          | 135 | 141 | 109 | 19 | 4 | 7 | 19 | 118.3 | 125          | 126  | 90 | 33 | 26 | 4.5        | 4 |

# ISO標準型アンバランス・シール

## ISO Standard Unbalance Seal

### TYPE **UO12-R1** (T3-04023)

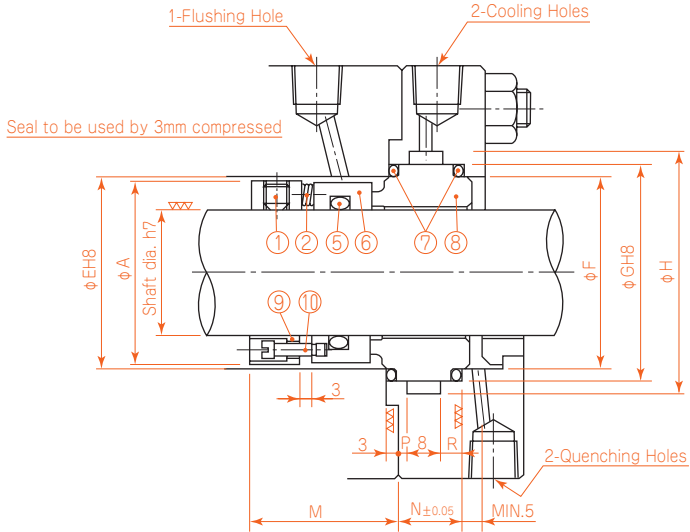

### TYPE **UO12-R2** (T3-07649)

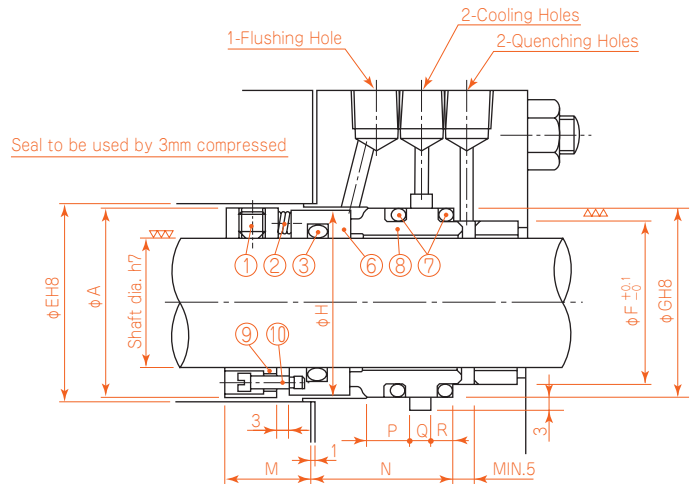

| No. | Parts Name     | Q'ty | No. | Parts Name      | Q'ty |
|-----|----------------|------|-----|-----------------|------|
| 1   | Set screws     | List | 7   | Insert packings | 2    |
| 2   | Springs        | List | 8   | Insert          | 1    |
| 5   | Shaft packings | 1    | 9   | Coller          | 1    |
| 6   | Seal ring      | 1    | 10  | Spring pins     | List |

Pressure -0.03~0.5MPa  
 Temp. Water and so on  
 Up to 90°C (for above 90°C,  
 cooler must be used)  
 Oil and so on  
 Up to 140°C (for above 140°C,  
 cooler must be used)

Synthetic rubber Oring used for  
 shaft packing.

| 寸法表 Dimension |     |     |              |     |     |    |    |   |   |              |     |      |    |    |    |   |   | 部品数量表 Q'ty |    |   |
|---------------|-----|-----|--------------|-----|-----|----|----|---|---|--------------|-----|------|----|----|----|---|---|------------|----|---|
| SHAFT DIA     | A   | E   | UO12-R1 Type |     |     |    |    |   |   | UO12-R2 Type |     |      |    |    |    |   |   | ①          | ②  | ③ |
|               |     |     | F            | G   | H   | M  | N  | P | R | F            | G   | H    | M  | N  | P  | Q | R |            |    |   |
| 20            | 34  | 36  | 36           | 42  | 48  | 34 | 15 | 2 | 5 | 28           | 34  | 34.5 | 18 | 33 | 10 | 5 | 5 | 2          | 4  | 2 |
| 22            | 36  | 38  | 38           | 44  | 50  | 36 | 15 | 2 | 5 | 30           | 36  | 36.5 | 20 | 33 | 10 | 5 | 5 | 2          | 4  | 2 |
| 24            | 39  | 40  | 40           | 46  | 52  | 36 | 15 | 2 | 5 | 32           | 38  | 38.5 | 20 | 33 | 10 | 5 | 5 | 2          | 4  | 2 |
| 25            | 40  | 41  | 41           | 47  | 53  | 36 | 15 | 2 | 5 | 33           | 39  | 39.5 | 20 | 33 | 10 | 5 | 5 | 2          | 4  | 2 |
| 26            | 41  | 42  | 42           | 48  | 54  | 36 | 15 | 2 | 5 | 34           | 40  | 40.5 | 20 | 33 | 10 | 5 | 5 | 2          | 4  | 2 |
| 28            | 43  | 44  | 44           | 50  | 56  | 36 | 15 | 2 | 5 | 36           | 42  | 42.5 | 20 | 33 | 10 | 5 | 5 | 2          | 4  | 2 |
| 30            | 45  | 46  | 46           | 52  | 58  | 36 | 15 | 2 | 5 | 38           | 44  | 44.5 | 20 | 33 | 10 | 5 | 5 | 2          | 6  | 2 |
| 32            | 47  | 48  | 48           | 54  | 60  | 36 | 15 | 2 | 5 | 40           | 46  | 46.5 | 20 | 33 | 10 | 5 | 5 | 2          | 6  | 2 |
| 33            | 48  | 49  | 49           | 55  | 61  | 36 | 15 | 2 | 5 | 41           | 47  | 47.5 | 20 | 33 | 10 | 5 | 5 | 2          | 6  | 2 |
| 35            | 50  | 51  | 51           | 57  | 63  | 36 | 15 | 2 | 5 | 43           | 49  | 49.5 | 20 | 33 | 10 | 5 | 5 | 2          | 6  | 2 |
| 38            | 55  | 58  | 58           | 64  | 70  | 39 | 15 | 2 | 5 | 50           | 56  | 56.5 | 20 | 38 | 10 | 6 | 6 | 2          | 8  | 4 |
| 40            | 57  | 60  | 60           | 66  | 72  | 39 | 15 | 2 | 5 | 52           | 58  | 58.5 | 20 | 38 | 10 | 6 | 6 | 2          | 8  | 4 |
| 43            | 60  | 63  | 63           | 69  | 75  | 39 | 15 | 2 | 5 | 55           | 61  | 61.5 | 20 | 38 | 10 | 6 | 6 | 2          | 8  | 4 |
| 45            | 62  | 65  | 65           | 71  | 77  | 39 | 15 | 2 | 5 | 57           | 63  | 63.5 | 20 | 38 | 10 | 6 | 6 | 2          | 8  | 4 |
| 48            | 65  | 68  | 68           | 74  | 80  | 39 | 15 | 2 | 5 | 60           | 66  | 66.5 | 20 | 38 | 10 | 6 | 6 | 2          | 8  | 4 |
| 50            | 68  | 70  | 70           | 76  | 82  | 43 | 17 | 3 | 6 | 62           | 68  | 68.5 | 24 | 38 | 10 | 6 | 6 | 2          | 12 | 4 |
| 53            | 71  | 73  | 73           | 79  | 85  | 43 | 17 | 3 | 6 | 65           | 71  | 72.5 | 24 | 38 | 10 | 6 | 6 | 2          | 12 | 4 |
| 55            | 73  | 75  | 75           | 81  | 87  | 43 | 17 | 3 | 6 | 67           | 73  | 73.5 | 24 | 38 | 10 | 6 | 6 | 2          | 12 | 4 |
| 58            | 76  | 83  | 83           | 89  | 95  | 43 | 17 | 3 | 6 | 72           | 78  | 80   | 24 | 38 | 10 | 6 | 6 | 2          | 12 | 4 |
| 60            | 78  | 85  | 85           | 91  | 97  | 43 | 17 | 3 | 6 | 74           | 80  | 82   | 24 | 38 | 10 | 6 | 6 | 2          | 12 | 4 |
| 63            | 81  | 88  | 88           | 94  | 100 | 43 | 17 | 3 | 6 | 77           | 83  | 85   | 24 | 38 | 10 | 6 | 6 | 2          | 12 | 4 |
| 65            | 83  | 90  | 90           | 96  | 102 | 43 | 17 | 3 | 6 | 79           | 85  | 87   | 24 | 38 | 10 | 6 | 6 | 2          | 12 | 4 |
| 68            | 88  | 93  | 93           | 99  | 105 | 44 | 17 | 3 | 6 | 84           | 90  | 91   | 25 | 41 | 11 | 8 | 6 | 2          | 16 | 4 |
| 70            | 90  | 95  | 95           | 101 | 107 | 44 | 17 | 3 | 6 | 86           | 92  | 93   | 25 | 41 | 11 | 8 | 6 | 2          | 16 | 4 |
| 75            | 95  | 104 | 104          | 110 | 116 | 44 | 17 | 3 | 6 | 91           | 97  | 100  | 25 | 41 | 11 | 8 | 6 | 2          | 16 | 4 |
| 80            | 100 | 109 | 109          | 115 | 121 | 44 | 17 | 3 | 6 | 99           | 105 | 106  | 25 | 41 | 11 | 8 | 6 | 2          | 16 | 4 |
| 85            | 105 | 114 | 114          | 120 | 126 | 46 | 19 | 4 | 7 | 104          | 110 | 111  | 27 | 41 | 11 | 8 | 6 | 2          | 16 | 4 |
| 90            | 110 | 119 | 119          | 125 | 131 | 46 | 19 | 4 | 7 | 109          | 115 | 116  | 27 | 41 | 11 | 8 | 6 | 2          | 16 | 4 |
| 95            | 115 | 124 | 124          | 130 | 136 | 46 | 19 | 4 | 7 | 114          | 120 | 121  | 27 | 41 | 11 | 8 | 6 | 2          | 16 | 4 |
| 100           | 122 | 129 | 129          | 135 | 141 | 47 | 19 | 4 | 7 | 119          | 125 | 126  | 28 | 41 | 11 | 8 | 6 | 3          | 20 | 4 |

# ISO標準型アンバランス・シール

## ISO Standard Unbalance Seal

TYPE **UO<sup>51</sup><sub>52</sub>-R2** (T3-07650)

UO51...Clockwise Spring (CCW look at atm.)  
UO52...Counter-clockwise Spring (CW look at atm.)

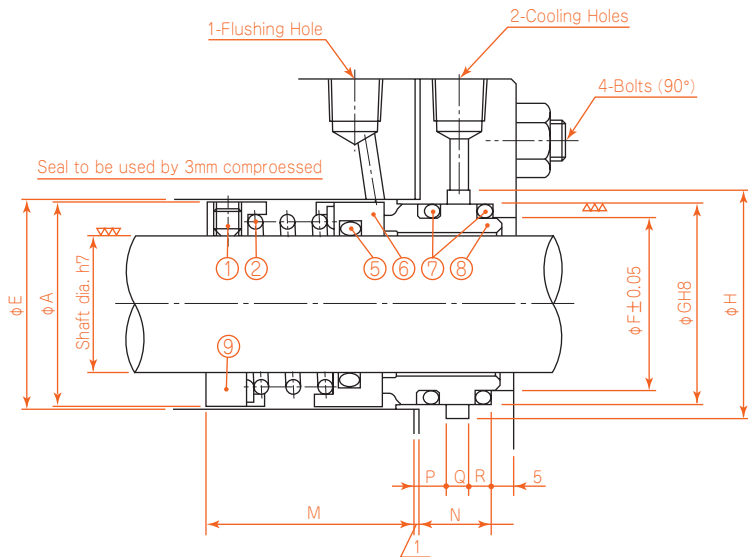

| No. | Parts Name      | Q'ty |
|-----|-----------------|------|
| 1   | Set screws      | List |
| 2   | Springs         | 1    |
| 5   | Shaft packings  | 1    |
| 6   | Seal ring       | 1    |
| 7   | Insert packings | 2    |
| 8   | Insert          | 1    |
| 9   | Coller          | 1    |

Pressure -0.03~0.5MPa  
Temp. Water and so on  
Up to 90°C (for above 90°C,  
cooler must be used)  
Oil and so on  
Up to 140°C (for above 140°C,  
cooler must be used)

Synthetic rubber Oring used for shaft packing.

| 寸法表 Dimension |     |     |     |     |     |    |    |   |   |   |  | 部品数量表 Q'ty |  |
|---------------|-----|-----|-----|-----|-----|----|----|---|---|---|--|------------|--|
| SHAFT DIA.    | A   | E   | F   | G   | H   | M  | N  | P | Q | R |  | ①          |  |
| 20            | 34  | 36  | 28  | 34  | 40  | 43 | 16 | 6 | 5 | 5 |  | 2          |  |
| 25            | 40  | 41  | 33  | 39  | 45  | 43 | 16 | 6 | 5 | 5 |  | 2          |  |
| 30            | 45  | 46  | 38  | 44  | 50  | 46 | 16 | 6 | 5 | 5 |  | 2          |  |
| 35            | 50  | 51  | 43  | 49  | 55  | 46 | 16 | 6 | 5 | 5 |  | 2          |  |
| 40            | 57  | 60  | 52  | 58  | 64  | 52 | 18 | 6 | 6 | 6 |  | 2          |  |
| 45            | 62  | 65  | 57  | 63  | 69  | 57 | 18 | 6 | 6 | 6 |  | 2          |  |
| 50            | 68  | 70  | 62  | 68  | 74  | 62 | 18 | 6 | 6 | 6 |  | 2          |  |
| 55            | 73  | 75  | 67  | 73  | 79  | 65 | 18 | 6 | 6 | 6 |  | 2          |  |
| 60            | 78  | 85  | 74  | 80  | 86  | 67 | 18 | 6 | 6 | 6 |  | 2          |  |
| 65            | 83  | 90  | 79  | 85  | 91  | 69 | 18 | 6 | 6 | 6 |  | 2          |  |
| 70            | 90  | 95  | 86  | 92  | 98  | 72 | 21 | 7 | 8 | 6 |  | 2          |  |
| 75            | 95  | 104 | 91  | 97  | 103 | 77 | 21 | 7 | 8 | 6 |  | 2          |  |
| 80            | 100 | 109 | 99  | 105 | 111 | 77 | 21 | 7 | 8 | 6 |  | 2          |  |
| 85            | 105 | 114 | 104 | 110 | 116 | 77 | 21 | 7 | 8 | 6 |  | 2          |  |
| 90            | 110 | 119 | 109 | 115 | 121 | 77 | 21 | 7 | 8 | 6 |  | 2          |  |
| 95            | 115 | 124 | 114 | 120 | 126 | 82 | 21 | 7 | 8 | 6 |  | 2          |  |
| 100           | 122 | 129 | 119 | 125 | 131 | 82 | 21 | 7 | 8 | 6 |  | 3          |  |

Speed-Pressure Limit

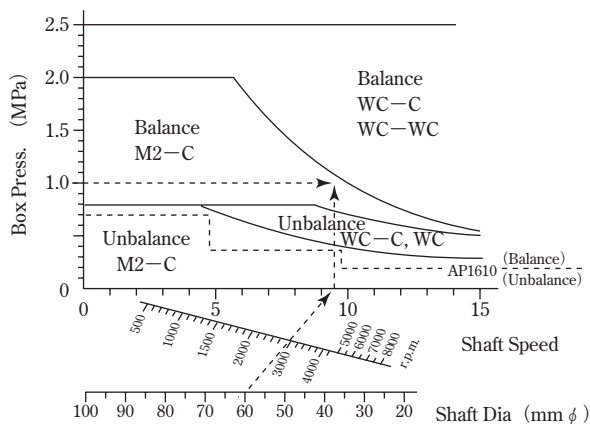

Temperature Limit

| Liquid           | Temperature °C          |   |     |     |     |
|------------------|-------------------------|---|-----|-----|-----|
|                  | -100                    | 0 | 100 | 200 | 300 |
| Water & Solution | -50 to 80: M2-C         |   |     |     |     |
|                  | 80 to 115: L□B-C        |   |     |     |     |
|                  | 115 to 170: L□S-C (L□S) |   |     |     |     |
| Oil & Hydro C.   | 120 to 170: M2-C        |   |     |     |     |
|                  | 170 to 300: L□B-C       |   |     |     |     |
|                  | 300 to 400: L□S-C (L□S) |   |     |     |     |

クーラー不要 NO COOLER

クーラー要 COOLER USE

材質記号Material Code

C : カーボン CARBON  
M2 : セラミックコーティング CERAMIC COATING  
L□B : 超硬合金(焼嵌式) WC (SHRINKAGE)  
L□S : 超硬合金(単体) WC (SOLID)



## 株式会社タンケンシールセーコウ

〒146-0093 東京都大田区矢口3丁目14番15号  
TEL 03 (3750) 2151 (代) FAX 03 (3750) 5171  
<http://www.tankenseal.co.jp>

### ■営業所

|                          |  |   |
|--------------------------|--|---|
| 東京営業所                    | 〒146-0093 東京都大田区矢口3丁目14番地15号<br>TEL 03 (3750) 2154 FAX 03 (3750) 5171          | E-mail <a href="mailto:tokyo@tankenseal.co.jp">tokyo@tankenseal.co.jp</a>         |
| 横浜営業所                    | 〒220-0072 神奈川県横浜市西区浅間町1丁目13番地5号藤江ビル5F<br>TEL 045 (322) 9977 FAX 045 (322) 9979 | E-mail <a href="mailto:yokohama@tankenseal.co.jp">yokohama@tankenseal.co.jp</a>   |
| 千葉営業所                    | 〒290-0056 千葉県市原市五井2783<br>TEL 0436 (22) 0512 FAX 0436 (22) 4889                | E-mail <a href="mailto:chiba@tankenseal.co.jp">chiba@tankenseal.co.jp</a>         |
| 四日市営業所                   | 〒510-0064 三重県四日市市新正2丁目6番地25号<br>TEL 0593 (53) 0275 FAX 0593 (53) 6177          | E-mail <a href="mailto:yokkaichi@tankenseal.co.jp">yokkaichi@tankenseal.co.jp</a> |
| 大阪営業所                    | 〒553-0003 大阪府大阪市福島区福島5丁目6番地31号堀内ビル<br>TEL 06 (6458) 9112 FAX 06 (6458) 2740    | E-mail <a href="mailto:osaka@tankenseal.co.jp">osaka@tankenseal.co.jp</a>         |
| 水島営業所                    | 〒712-8034 岡山県倉敷市水島西栄町15-23<br>TEL 086 (446) 6655 FAX 086 (446) 6485            | E-mail <a href="mailto:mizushima@tankenseal.co.jp">mizushima@tankenseal.co.jp</a> |
| 広島営業所                    | 〒732-0824 広島県広島市南区的場町2丁目5番地9号サンコウビル<br>TEL 082 (262) 2208 FAX 082 (263) 9093   | E-mail <a href="mailto:hiroshima@tankenseal.co.jp">hiroshima@tankenseal.co.jp</a> |
| 徳山営業所                    | 〒745-0042 山口県周南市野上町2-38白神ビル<br>TEL 0834 (21) 0468 FAX 0834 (31) 4549           | E-mail <a href="mailto:tokuyama@tankenseal.co.jp">tokuyama@tankenseal.co.jp</a>   |
| 北海道出張所                   | 〒066-0037 北海道千歳市新富1丁目7番地5号平和ビル1F・B号<br>TEL 0123 (42) 3581 FAX 0123 (42) 3582   | E-mail <a href="mailto:hokkaido@tankenseal.co.jp">hokkaido@tankenseal.co.jp</a>   |
| タンケンエンジニアリング(株)<br>新潟事業所 | 〒959-0262 新潟県西蒲原郡吉田町若生町14-13<br>TEL 0256 (92) 7438 FAX 0256 (92) 7448          | E-mail <a href="mailto:tek@tankenseal.co.jp">tek@tankenseal.co.jp</a>             |

### ■工場

|            |                             |                                       |
|------------|-----------------------------|---------------------------------------|
| 辰野工場       | 〒399-0428 長野県上伊那郡辰野町伊那富30   | TEL 0266 (41) 2501 FAX 0266 (41) 4192 |
| 茅ヶ崎工場      | 〒253-0085 神奈川県茅ヶ崎市矢畑995     | TEL 0467 (85) 2501 FAX 0467 (59) 1011 |
| 吉川エヌシーセンター | 〒949-3447 新潟県上越市吉川区竹直1068-2 | TEL 025 (548) 3700 FAX 025 (548) 3548 |

### ■代理店

|       |                           |                                       |
|-------|---------------------------|---------------------------------------|
| 全国地区  | (株) パシフィックソーワ             | TEL 03 (5540) 1234 FAX 03 (5540) 1235 |
| 北海道地区 | 佐々木機工(株)                  | TEL 0143 (44) 5428 FAX 0143 (46) 4055 |
| 東北地区  | キクニ(株)                    | TEL 022 (365) 3311 FAX 022 (364) 3373 |
| 鹿島地区  | カシマ産業(株)                  | TEL 0479 (46) 0007 FAX 0479 (46) 2272 |
| 北陸地区  | 富山通商(株)                   | TEL 0764 (29) 0477 FAX 0764 (29) 0907 |
| 広島地区  | エヌエスケー販売(株) 西日本カンパニー・中国支社 | TEL 082 (285) 7760 FAX 082 (283) 9491 |
| 坂出地区  | 愛光産業(有)                   | TEL 0877 (62) 5385 FAX 0877 (62) 5391 |
| 松山地区  | 佐々木商事(株)                  | TEL 0899 (26) 6050 FAX 0899 (26) 6062 |
| 九州地区  | 岡野商事(株)                   | TEL 093 (381) 3561 FAX 093 (371) 1502 |